

ILLUSTRATED REPORT FOR ANY CUT

Step Cut 23.04.2008

Model: Simple
 Expert name: Makoed A.G.
 Real weight, ct:
 Calculated weight, ct: 2.56, 2.5621
 Spread: -0.02 ct, -0.94 %
 Extra Facet / Nat: Yes (1)

Width	Length	Ratio (L/W)	Diameter Minimum	Diameter Maximum
9.051 mm	10.725 mm	1.185	9.051 mm	10.725 mm

Total height	Crown height	Pav. depth	Girdle	
			Bezel	Valley
4.291 mm	0.915 mm	3.101 mm	0.275 mm	N/A mm
47.41 %				

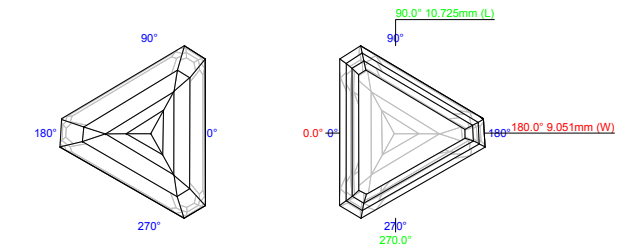
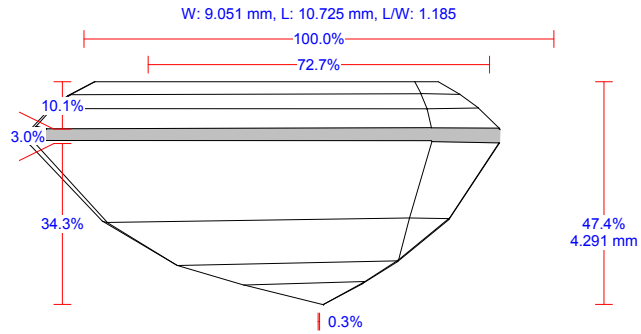

Appraiser title: AGS_2005
 Overall cut quality: N/A
 Symmetry appraiser title: Internal
 Overall symmetry quality: PR

Color	
Clarity	
Polish	
luorescence	

Parameter	Avg	Min	Max	Dev
Diameter, mm		9.051	10.725	18.49 %
Crown height, %	10.11	9.86	10.60	0.75
Crown height, mm	0.915	0.892	0.960	0.068
Pavilion depth, %	34.27	33.70	34.88	1.18
Pavilion depth, mm	3.101	3.050	3.157	0.106
Girdle Bezel, %	3.04	2.68	3.33	0.66
Girdle Bezel, mm	0.275	0.242	0.302	0.059
Girdle Valley, %	N/A	N/A	N/A	N/A
Girdle Valley, mm	N/A	N/A	N/A	N/A
Table, %		72.31	73.19	0.88
Table, mm		6.624	6.758	0.134
Culet, %		0.31	0.37	0.06
Culet, mm		0.028	0.033	0.005

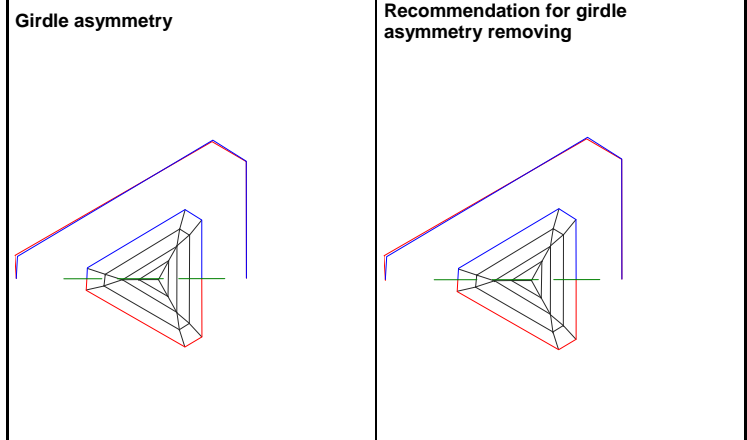
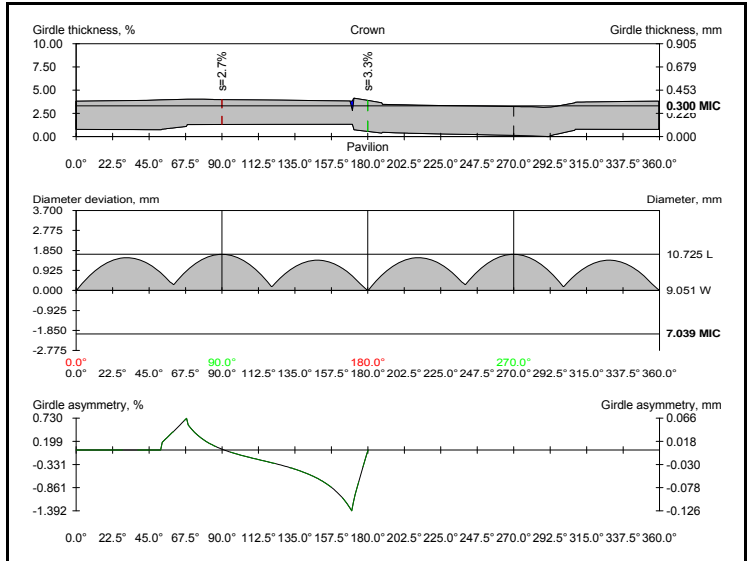

Girdle-Culet offset by table axis	1.49 ± 0.71, %	0.135 ± 0.064, mm
Girdle-Table offset by table axis	0.27 ± 0.69, %	0.024 ± 0.062, mm
Table-Culet offset by table axis	1.73 ± 0.72, %	0.157 ± 0.065, mm

